

Vetina CS5 Series

Endoscope Camera System



The equipment adopts modular design, can be connected with endoscopes, light sources and monitors to provide real-time white images for intraoperative. The connection is shown as below:

Endoscope Camera System

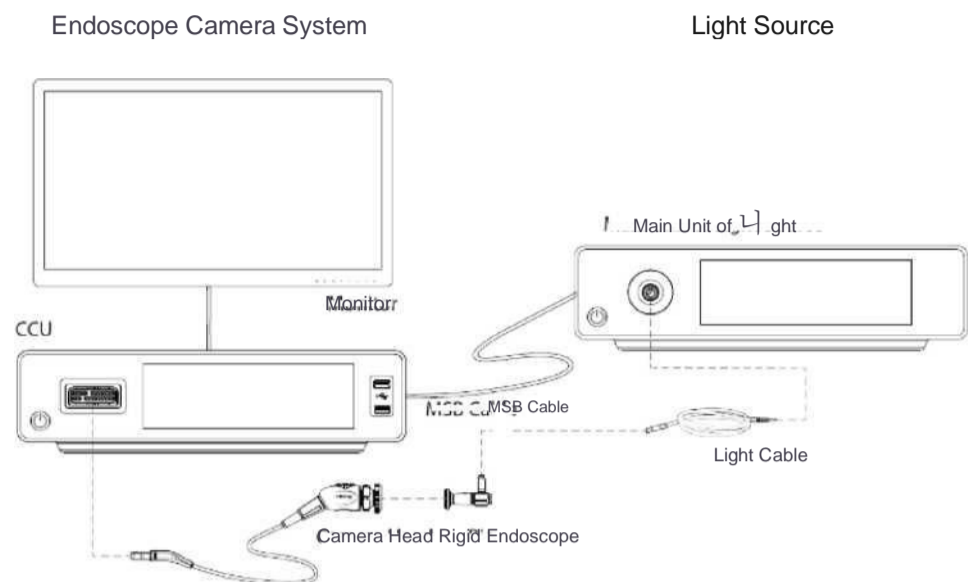

Dimension	380mm X 350mm X 80mm
Weight(CCUCU)	≤ 10 kg
Weight(White light Camera head)	≤ 190 g (excluding the cable)
Resolution	3840*2160 or 4096*2160 pixels
Image Sensor	1- chip 4K CMOS
Scan Mode	Progressive
Refresh Rate	50/60 Hz
Signal Output	12G-SDI x1, HDMI x2, DVI x1, 3G-SDI x 1
Data Management	FuH HD Recording with Built-in USB Storage Flash Disk (up to 6TB)
Protection Against Moisture	Camera head IPX7
Protection Against Electric shock	Class I DEFIBRILLATION-PROOF Type CF

Differences Among Models

Model	Color Style			
	Standard	Bright	Gentle	Vivid
CS5	√	√	√	√
CS5 Ultra	√	√	√	√

Endoscope Light Source

Dimension	380mm x 350mm x 80mm
Weight	≤ 10Kg
Lamp	High Brightness White LED
Power consumption	260VA
Lamp Life	Over 60,000h
Color Temperature	3000-7000K
Protection Against Electric Shock	Class I, Type CF
Intensity	23000000Lux (max center)
Noise	<55dB

Color rendering index ≥ 90, in the white light mode

24"/32" 4K Monitor

LCD Size	32/24 inch
Weight	5.1 Kg(24 inch) 14.7Kg(32inch)
Resolution	3840*2160 pixels
Contrast Ratio	1200:1 (24 inch) 1000:1 (32 inch)
Refresh Rate	50/60 Hz
Backlight Brightness	305 cd/m (24" Monitor) 1000 cd/m (32" Monitor)
Input Signal	24inch: HDMI*3, DP*1; 32inch: DP*1, HDMI*1, DVI*2, SDI*2, RS232*1, USB3.0*2
Max Viewing Angel	178°
Loop Out	N (24inch)
Picture in Picture	Yes

Insufflator

Model	GS5	GS5 Ultra
Flow Rate	0.1-50L/ min	0.1-50L/ min
Heating	X	√
Smoke Evacuation	X	√
Modes	4	4
Touch Screen	√	√

Dimension	380mm x 350mm x 141 mm
Voight	10.0Kg
Pressure Range	1 - 30mmHg
Modes	Canine, Feline, Others, Customized
Heating function(HS-50F/HS-50H)	Yes, Temperature <41℃
Display	7 inch color touch screen
Protection against harmful ingress of water or particulate matter	Foot pedal IPX8 The insufflator is an ordinary-type device (sealed device that does not protect from liquid inlet)
Protection against electric shock	Type CF
Method of sterilization	By other methods validated and described by the manufacturer

Laparoscope

Model	Field of View	Direction of View	Working Length	Max. Width of Insertion Portion
LP530	80° ±15%	30°±10°	290mm ±3%	φ5mm
LP5430M	80 ±15%	30°±10°	330mm ±3%	φ5mm

Mobile Trolley for CS5 Ultra

Part number 045-00002A-00

Mobile trolley Dimension	520mm x 470mm x 1204mm
Shelf Dimension	510mm X 470mm
Drawer Dimension	510 mm x 450mm x 150mm
Weight of the Mobile Trolley	<59kg(excluding the optional modules)
Flexible Endo arm Load capacity	<7 kg
Shelf Load capacity	<30 kg
CO2 holder assembly Load capacity	<12kg
Total load capacity Load capacity	<112kg

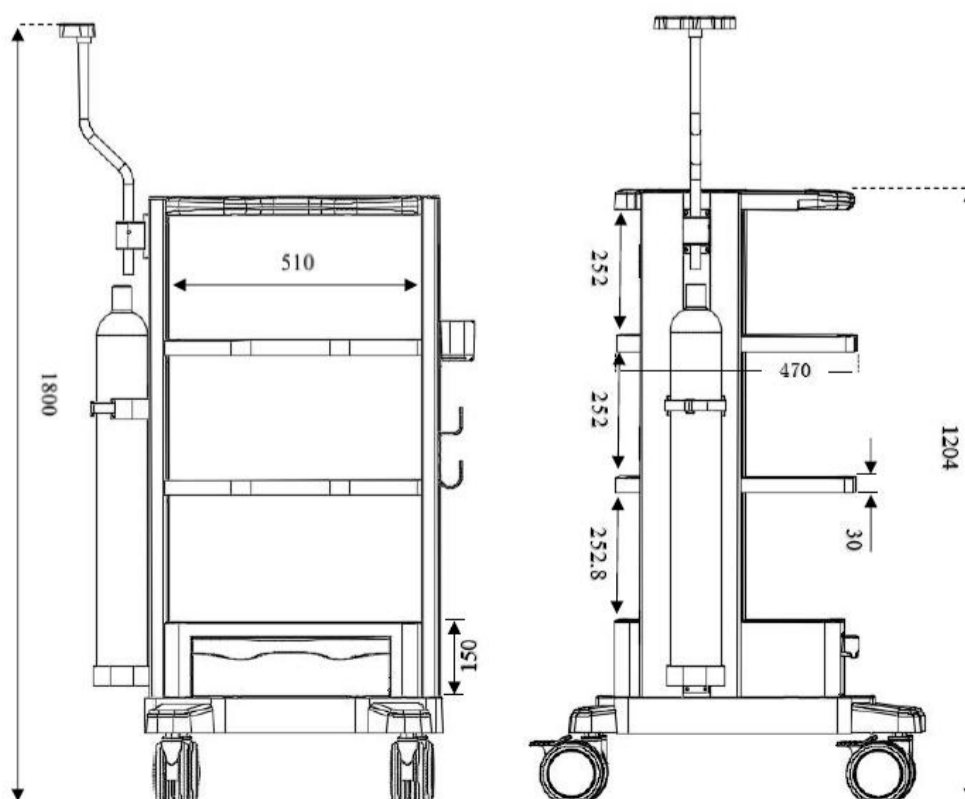

Mobile Trolley for CS5

Part number 045-00122A-00

Mobile trolley Dimension	473mm x 430mm x 1003mm
Shelf Dimension	400mm X 430mm
Weight of the Mobile Trolley	<30 kg(excluding the optional modules)
Flexible Endo arm Load capacity	<7 kg
Shelf Load capacity	<10 kg
CO2 holder assembly Load capacity	<12kg
Total load capacity Load capacity	<112kg

